

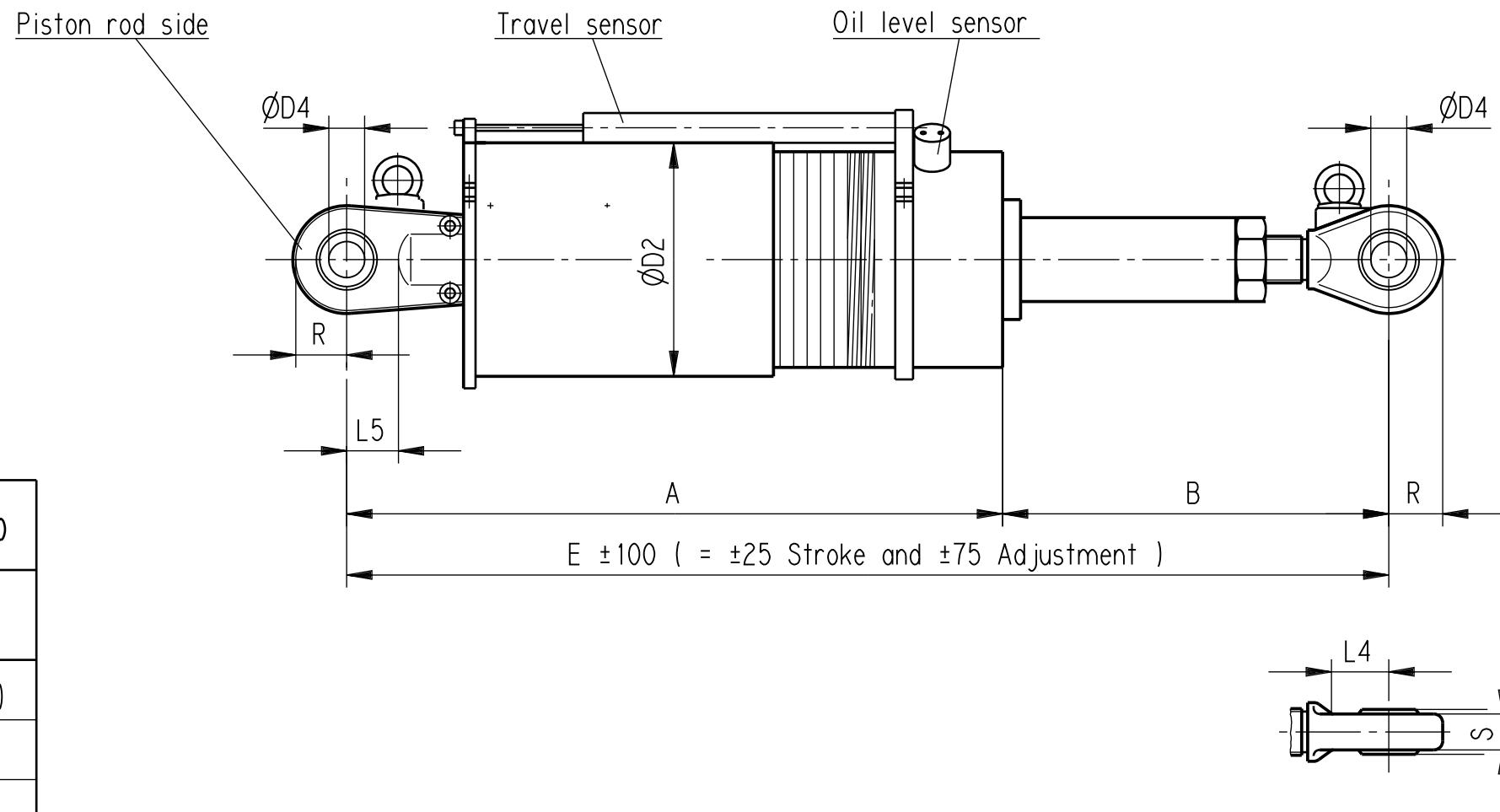

Type	306256-R10	308256-R50
max. faulted load [kN]	98.1	490.5
Stroke	100(+50)	100(+50)
A min	480	620
A max	580	720
B	340	415
ØD2	170	270
ØD4	30	60
E min	820±100	1035±100
E max	920±100	1135±100
L4	66	90
L5	70	110
R	36,5 \triangle_3	100
S	23 \triangle_3	50
SG	32	63
Weight	40 kg \triangle_3	160 kg \triangle_3



EA-Nr. : 10191

General Tolerances DIN ISO 2768-m		Special Snubber Type 30				
3	Weight added 306256-R10: R,S changed	13.08.19	Scale	2015	Datum	Name
2	Text geändert	18.03.15	Bearb.	11.02.	Duden	562470-3
1	306256-R10: A+B und EA-Nr. geändert	20.02.15	Gepr.			Zeichnungs Nr./Drawing no.
Nr	Revision	Bearb.	AV/QM/BMT			Bl./page Rev
						Fertigungsauftrags Nr./Serial no.